



## **FOREWORD**

*This document has been prepared based upon the evidences collected during the investigation and opinions obtained from the experts. The investigation has been carried out in accordance with Annex 13 to the convention on International Civil Aviation and under Rule 11 of Aircraft (Investigation of Accidents and Incidents), Rules 2017 of India. The investigation is conducted not to apportion blame or to assess individual or collective responsibility. The sole objective is to draw lessons from this serious incident which may help in preventing such incidents in future.*

<b>INDEX</b>		
<b>Para</b>	<b>Content</b>	<b>Page No.</b>
	<b>SYNOPSIS</b>	<b>6</b>
<b>1</b>	<b>FACTUAL INFORMATION</b>	<b>7</b>
1.1	HISTORY OF THE FLIGHT	7
1.2	INJURIES TO PERSONS	7
1.3	DAMAGE TO AIRCRAFT	7
1.4	OTHER DAMAGE	8
1.5	PERSONNEL INFORMATION	8
1.6	AIRCRAFT INFORMATION	9
1.7	METEOROLOGICAL INFORMATION	13
1.8	AIDS TO NAVIGATION	14
1.9	COMMUNICATIONS	14
1.10	AERODROME INFORMATION	14
1.11	FLIGHT RECORDERS	14
1.12	WRECKAGE AND IMPACT INFORMATION	14
1.13	MEDICAL AND PATHOLOGICAL INFORMATION	14
1.14	FIRE	14
1.15	SURVIVAL ASPECTS	14
1.16	TESTS AND RESEARCH	14
1.17	ORGANISATIONAL AND MANAGEMENT INFORMATION	16
1.18	ADDITIONAL INFORMATION	17
1.19	USEFUL OR EFFECTIVE INVESTIGATION TECHNIQUES	20
<b>2</b>	<b>ANALYSIS</b>	<b>20</b>
2.1	GENERAL	20
2.2	CIRCUMSTANCES LEADING TO THE INCIDENT	20
2.3	LPT 3 <sup>RD</sup> STAGE BLADE FAILURE & PREVENTIVE ACTION	21
<b>3</b>	<b>CONCLUSION</b>	<b>21</b>
3.1	FINDINGS	21
3.2	PROBABLE CAUSE OF THE INCIDENT	22
<b>4</b>	<b>SAFETY RECOMMENDATIONS</b>	<b>22</b>

## **GLOSSARY**

AAIB	Aircraft Accident Investigation Bureau, India
AMSL	Above Mean Sea Level
ARC	Airworthiness Review Certificate
ASR	Airport Surveillance Radar
ATC	Air Traffic Control
AUW	All Up Weight
C of A	Certificate of Airworthiness
C of R	Certificate of Registration
CAR	Civil Aviation Requirements
CPL	Commercial Pilot License
CVR	Cockpit Voice Recorder
DFDR	Digital Flight Data Recorder
DGCA	Directorate General of Civil Aviation
F/O	First Officer
FCOM	Flight Crew Operating Manual
FCTM	Flight Crew Training Manual
FRTOL	Flight Radio Telephone Operators License
IATA	International Air Transport Association
ICAO	International Civil Aviation Organization
ILS	Instrument Landing System
LLZ	Localizer
MEL	Minimum Equipment List
MLG	Main Landing Gear
MTOW	Maximum Take Off Weight
NDB	Non-Directional Beacon
NLG	Nose Landing Gear
NM	Nautical Miles
PA	Passenger Address
PF	Pilot Flying
PIC	Pilot in Command
PM	Pilot Monitoring
QRH	Quick Reference Handbook
RA	Radio Altitude
RESA	Runway End Safety Area
SB	Service Bulletin
SEP	Safety and Emergency Procedures Manual
VFR	Visual Flight Rules
VMC	Visual Meteorological Conditions
VOR	VHF Omnidirectional Range
UTC	Coordinated Universal Time

**FINAL INVESTIGATION REPORT ON SERIOUS INCIDENT TO M/S INDIGO AIRBUS  
A320 (NEO) AIRCRAFT VT-IZT ON 26/10/2019**

1.	<b>Aircraft Type</b>	:	Airbus A320-271 NEO
	<b>Nationality</b>	:	Indian
	<b>Registration</b>	:	VT - IZT
2.	<b>Owner</b>	:	M/s Klaatu Aircraft Leasing (Ireland) Limited
3.	<b>Operator</b>	:	Inter Globe Aviation Ltd (IndiGo)
3.	<b>Pilot – in –Command</b>	:	ATPL holder
	<b>Extent of Injuries</b>	:	Nil
4.	<b>First Officer</b>	:	CPL Holder
	<b>Extent of injuries</b>	:	Nil
5.	<b>Place of Serious Incident</b>	:	Enroute (Near Delhi)
6.	<b>Date &amp; Time of Incident</b>	:	26 <sup>th</sup> October 2019 & 0556 UTC
7.	<b>Last Point of Departure</b>	:	Delhi Airport
8.	<b>Point of Intended Landing</b>	:	Goa Airport
10.	<b>Type of Operation</b>	:	Scheduled Operation
11.	<b>Passengers on Board</b>	:	162 (Including 04 Cabin Crew Members)
	<b>Extent of Injuries</b>	:	Nil
12.	<b>Phase of Operation</b>	:	Climb
13.	<b>Type of Occurrence</b>	:	Air Turn Back due to Engine Stall (Commanded IFSD).

(All the timings in this report are in UTC unless otherwise specified)

## **SYNOPSIS**

On 26<sup>th</sup> October 2019, M/s Indigo Airbus A320-271 (NEO) aircraft VT-IZT, while operating a scheduled flight from Delhi to Goa was involved in a Serious Incident of Air Turn Back due to Engine Stall (Commanded In-Flight Shut Down of Engine) during climb.

The aircraft was under the command of an ATPL holder with a co-pilot a CPL holder. There were 162 passengers on board the aircraft including 04 cabin crew members.

The aircraft took –off from Delhi uneventfully. While climbing passing 28,200 feet altitude, a loud bang was heard by the crew and subsequently, Engine No # 2 STALL ECAM triggered. This was followed by “ENG 2 HGH VIB” on ECAM. The Engine parameters i.e., N1 vibrations was at 10 and N2 vibrations was at 8 and the EGT was noticed to be increasing past 1100°C. Thereafter, ENG 2 EGT OVERLIMIT also triggered on ECAM. As the Engine parameters were abnormal, the crew decided to divert back to Delhi. All the ECAM actions were carried out. The crew carried out “Commanded IFSD” of Engine # 2 during descent to Delhi. The aircraft was then diverted back to Delhi. The aircraft landed safely at Delhi. On visual inspection of the engine inlet area and exhaust area, all blades of LPT 3rd stage were found damaged.

The occurrence was classified as Serious Incident and an investigation to investigate into the probable cause(s) of the serious incident, was instituted under Rule 11 (1) of Aircraft (Investigation of Accidents and Incidents), Rules 2017.

# **1 FACTUAL INFORMATION**

## **1.1 History of the Flight**

On 26<sup>th</sup> October 2019, M/s Indigo Airbus A320-271 (NEO) aircraft VT-IZT, was scheduled to operate flight (flight No. 6E-329) from Delhi to Goa.

There was no abnormality reported on the aircraft during previous flights of the day. The aircraft was scheduled to depart from Delhi at 0525 UTC and arrive Goa at 0810 UTC. The aircraft took-off from Delhi at around 0534 UTC. At 0556 UTC, while climbing passing Flight Level 283, a loud bang was heard by the crew. Subsequently, ENG 2 STALL ECAM triggered. This was followed by “ENG 2 HGH VIB” on ECAM. The crew followed QRH/FCOM procedure. The Engine parameters i.e., N1 vibrations was at 10 and N2 vibrations was at 8 and the EGT was noticed to be increasing past 1100°C. Thereafter, ENG 2 EGT OVERLIMIT also triggered on ECAM. As the Engine parameters were abnormal, the crew decided to divert back to Delhi. The crew carried out ECAM procedures/Checklists but there was no reduction in vibration. The crew then carried out “Commanded IFSD” of Engine # 2 during descent. Accordingly, crew informed ATC, Delhi and the aircraft was diverted back to Delhi. After obtaining necessary clearances from ATC, Delhi, the aircraft landed safely at Delhi on single engine at 0623 UTC.

Upon landing, the aircraft vacated the runway and taxied to bay. The passengers were disembarked normally. There was no fire and no injury to any occupant on board the aircraft.

During post flight inspection, while carrying out visual inspection of the involved engine, i.e., inlet area and exhaust area of Engine # 2, Low Pressure Turbine 3rd stage blades were found damaged.

## **1.2 Injuries to Persons**

There was no injury to any of the occupant on board the aircraft.

## **1.3 Damage to Aircraft**

During post flight inspection and tear down examination the following salient damages on Engine # 2 were observed: -

1. During inspection of Low-Pressure Turbine (LPT) assembly, LPT Drive Shaft was observed to have contact damage (Rubbing).

2. LPT Stage 2 Vanes were found to have impact damaged and metal contamination on Trailing Edge.
3. LPT Stage 2 Disk was observed to have impact damage.
4. LPT Stage 3 Vanes were observed to have impact damage.
5. All LPT Stage 3 blades were found damaged (Fractured).
6. Turbine Exhaust Case was found to have impact damage.

#### 1.4 Other Damages

Nil

#### 1.5 Personnel Information

##### 1.5.1 Pilot – In – Command

Age	51
License	ATPL
Date of Issue	14/08/2016
Valid up to	13/08/2021
Category	AEROPLANE
Date of Class I Med. Exam.	11/07/2019
Class I Medical Valid up to	10/07/2020
Date of issue FRTOL License	14/08/2019
FRTOL License Valid up to	13/08/2024
Endorsements as PIC	04/02/2019
Total flying experience	8415:20 Hrs
Total flying experience on type	1386:35 Hrs
Last Flown on type	25/10/2019
Total flying experience during last 1 year	709:17 Hrs
Total flying experience during last 6 Months	369:22 Hrs
Total flying experience during last 30 days	49:53 Hrs
Total flying experience during last 07 Days	11:54 Hrs
Total flying experience during last 24 Hours	6.87 Hrs
Whether involved in Accident/incident earlier	No
Date of latest Flight Checks and Ground Classes	07/02/2019 (ALRC) 28/09/2019 (REFRESHER)



### 1.15.2 Co-Pilot

Age	36
License	CPL
Date of Issue	05/09/2019
Valid up to	04/09/2024
Category	AEROPLANE
Class I Medical Valid up to	08/05/2020
Date of issue FRTOL License	24/08/2018
FRTOL License Valid up to	23/08/2023
Endorsements as PIC	NA
Total flying experience	385:33
Total flying experience on type	160:33
Last Flown on type	25/10/2019
Total flying experience during last 1 year	160:33 Hrs
Total flying experience during last 6 Months	160:33 Hrs
Total flying experience during last 30 days	71:02 Hrs
Total flying experience during last 07 Days	22:16 Hrs
Total flying experience during last 24 Hours	6.87 Hrs
Whether involved in Accident/incident earlier	No
Date of latest Flight Checks and Ground Classes	21/09/2019 (ALRC) 18/03/2019 (REFRESHER)

## 1.6 Aircraft Information

### 1.6.1 Airbus A-320 Neo

The Airbus A320 is narrow-body (single-aisle) aircraft with a retractable tricycle landing gear and is powered by two wing pylon-mounted turbofan engines. The A320 family aircraft fitted with new engines were named as NEO (New Engine Option) and the rest were named as CEO (Current Engine Option). These new engines were manufactured with the idea that it will consume less fuel as compared to other engines, reduced CO2 emissions and reduction in engine noise. A320 NEO can be fitted with either:

- The PW1127G-JM, manufactured by Pratt & Whitney or;
- The LEAP-1A, manufactured by CFM International.

The A320 NEO aircraft made its first flight on 25th September 2014 and it was first introduced by Lufthansa on 20th January 2016. A total of 38 operators worldwide are

operating A320 NEO family aircraft. After acceptance of Type Certification by DGCA, these A320 NEO aircraft (fitted with PW1127G-JM engines) were inducted by two airline operators in India i.e., M/s Indigo and M/s Go Air.

M/s Indigo inducted the first A320 NEO aircraft in its fleet on 11th March 2016. The number of A320 NEO family fleet operating in India and globally (as of November 2020) is given below: -

	Airlines	A320 NEO		A321 NEO		Total
Global (Including India)	All	485		249		734
India	Indigo	115	161	25	25	186
	Go Air	46		0		

**Table 1: A320/A321 Neo fleet Global vs India.**

### 1.6.2 Brief Technical Description of NEO Engine

The PW1127G-JM turbofan engine is an axial-flow, twin spool turbofan engine with an ultra-high bypass ratio, low speed gear-driven fan.

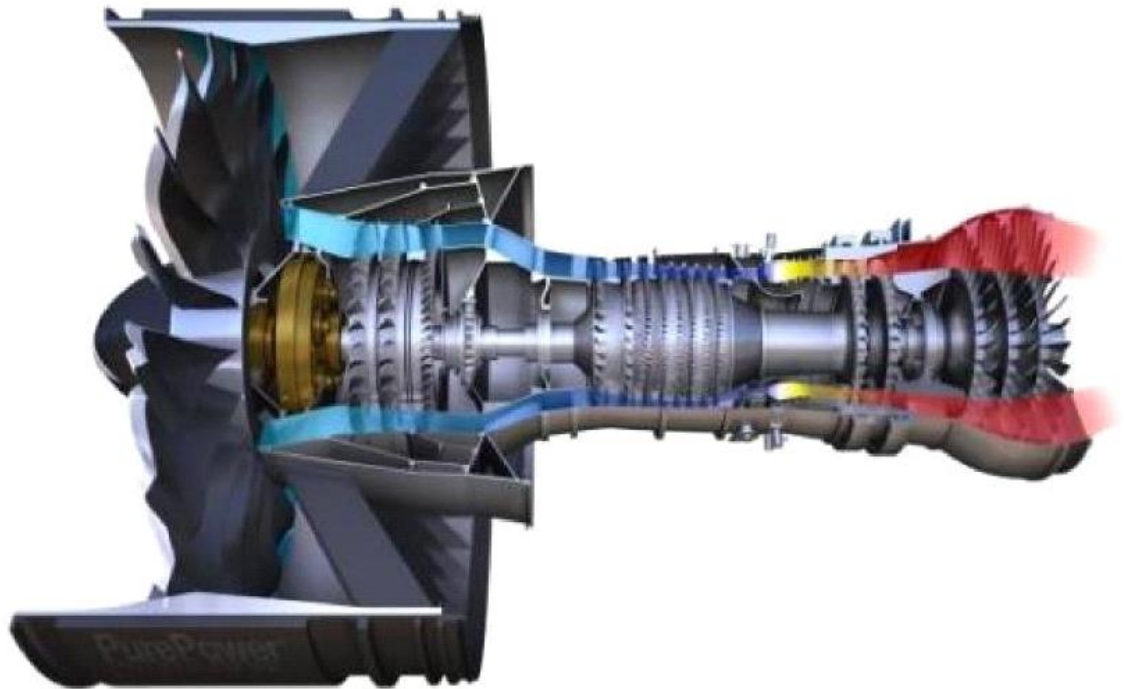
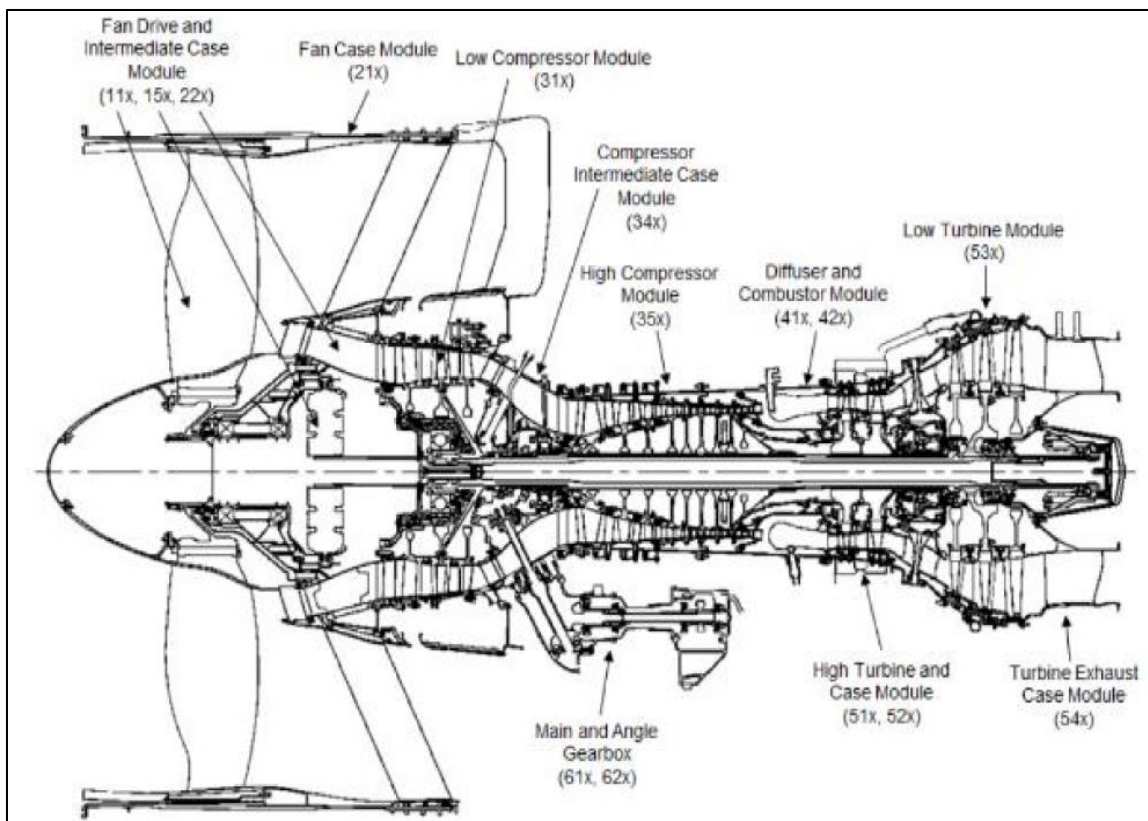

**Figure 1: ENGINE CROSS SECTION**

The engine comprises of following Modules/Build Groups as shown below: -

1. Fan Rotor Group	13. High Compressor Front Case Group
2. Fan Drive Bearing Group	14. High Compressor Rotor Group

3. Fan Drive Gear Group	15. Diffuser Case Group
4. Fan Intermediate Case Group	16. Combustor and Turbine Nozzle Group
5. No. 2 Bearing Group	17. High Turbine Stator Group
6. Fan Case Group	18. High Turbine Rotor Group
7. Low Compressor Stator Group	19. Turbine Intermediate Case Group
8. Low Compressor Rotor Group	20. Low Turbine Stator Group
9. 2.5 Bleed Group	21. Low Turbine Rotor Group
10. Compressor Intermediate Case Group	22. Turbine Exhaust Case Group
11. No. 3 Bearing Group	23. Main Gearbox Group
12. High Compressor Rear Stator Group	24. Angle Gearbox Group



**Figure 2: Engine Modules/ Build Group**

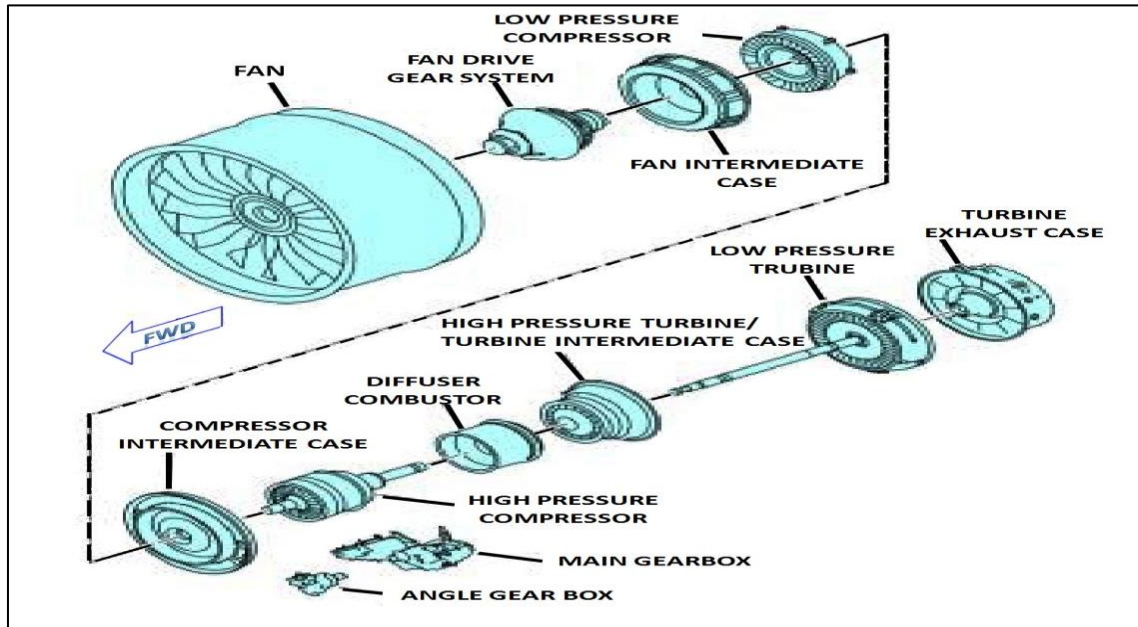

**Figure 3: Engine Modules/ Build Group**

**1.6.3 Aircraft VT-IZT General Information**

Aircraft Model	A320-271N
MSN	8789
Year of Manufacturer	2019
Name of Owner	M/s KLAATU AIRCRAFT LEASING (IRELAND) LIMITED
C of R	5046/2
C of A	7149
Category	Normal
C of A Validity	NO VALIDITY
A R C issued	08-03-2019
ARC valid up to	07-03-2020
Aircraft Empty Weight	42351.385 Kg
Maximum Takeoff weight	74000.00 Kg
Date of Aircraft weighment	13-02-2019
Operating Empty Weight	43333.762 Kg
Max Usable Fuel	18622.000 Kg
Max Payload with full fuel	12044.238 Kg
Operating Empty Weight C.G	25.647 % MAC
Next Weighing due	13-02-2024
Total Aircraft Hours	2372:03

Last major inspection	3000FH/ 360 Days on 22-10-2019
List of Repairs carried out after last major inspection till date of incidence:	NIL
Engine Type	PW1127G-JM
Date of Manufacture LH	18-12-2018
Engine Sl. No. LH	P771135
Last major inspection (LH)	3000FH/ 360 Days on 22-10-2019
List of Repairs carried out after last major inspection till date of incidence:	NIL
Total Engine Hours/Cycles LH	2372:03/1656
Date of Manufacture RH	18-01-2019
Engine Sl. No. RH	P771192
Last major inspection (RH)	3000FH/ 360 Days on 22-10-2019
List of Repairs carried out after last major inspection till date of incidence:	NIL
Total Engine Hours/Cycles RH:	2372:03/1656
Aero mobile License	31-05-2024
AD, SB, Modification complied (LH ENGINE):	All Applicable AD, SB & Modification are complied.
AD, SB, Modification complied (RH ENGINE):	All Applicable AD, SB & Modification are complied.

All concerned Airworthiness Directives, mandatory Service Bulletins, and DGCA Mandatory Modifications on this aircraft and its engines were complied with as on date of event.

### 1.7 Meteorological Information

Enroute weather information is given below: -

- VIDP 260500Z 19003KT 1600 R28/2000 R29/2000 FU NSC 27/15 Q1016 NOSIG=
- VIDP 260530Z 23003KT 2000 FU NSC 28/15 Q1016 NOSIG=
- VIDP 260600Z 19003KT 2000 FU NSC 28/15 Q1016 NOSIG=
- VIDP 260630Z 14005KT 2000 FU NSC 29/15 Q1015 NOSIG=

However, weather has no relevance to the subject incident.



As per agreement between M/s Indigo and OEM, the damaged engine was replaced with a serviceable engine. The damaged LH engine was sent to OEM after the incident. The Engine was inducted in OEM's facility and, Engine Disassembly and Inspection was carried out. There were several similar occurrences involving the failure of LPT 3<sup>rd</sup> stage blades preceding this incident. The LPT 3<sup>rd</sup> stage blade failure was considered to be a known issue, which had a developed corrective action in place. No Technical Investigation was carried out by the OEM on the Engine ESN # P771192.

During Disassembly and subsequent Inspection, hardware affected by impact damage was repaired or replaced as required as per the Shop Report made available by the OEM. A new LPT 3 rotor was installed as per SB 72-00-0111. The combustor and fuel nozzles were replaced with new as per applicable SBs. The T1 vanes were replaced with new. The HPT module was removed and new HPT module was installed as per applicable SBs. A new engine data plate was installed. EEC software was upgraded to FCS 6.0.

#### **1.16.2 Failure Analysis Report from National Aerospace Laboratories, Bengaluru**

AAIB, India got the fractured blades from Engine ESN P770187, P770530 and P770516 which had failed during different flights tested at National Aerospace Laboratories (NAL), Bengaluru to carry out Failure Analysis on these blades.

NAL carried out failure analysis of these blades and submitted a report to AAIB. Following are the salient observations made in the failure report: -

- Examination revealed that all 78 LPT 3<sup>rd</sup> stage blades had fractured in the airfoil at varying heights from the blade root platform.
- Impact damages were found present predominantly along trailing edge (TE) of the available part of the airfoil.
- Fracture surfaces of the blades showed a flat appearance with vaguely delineated chevron marks emanating from the crack origins in many occasions.
- Fractography study confirmed that LPT 3<sup>rd</sup> stage blades had fractured instantaneously in a brittle manner. None of the blades showed presence of any signatures of progressive failure such as fatigue.
- Scanning electron fractography study confirmed that the crack propagation in the blades was by mixed mode of cleavage and interlamellar separation. In the fractured blades,

the fracture process in gamma-phase was by cleavage while it was by interlamellar separation in lamellar colonies.

- Metallurgical evaluation of the Material of Construction (MoC) showed that stage 3 LPT blades were made of a Gamma base Titanium Aluminide (TiAl), an intermetallic material. The MoC of the blades has the nominal composition of 52% Titanium (Ti), 43% Aluminium (Al), 4% Niobium (Nb) and 1% Molybdenum (Mo). The material did not have any metallurgical abnormalities that could be responsible for failure of the LPT blades.
- TiAl-base intermetallic materials are, in general, brittle in nature having low fracture toughness. Although, the alloy used for stage III LPT blades is an improved version of TiAl alloys with engineered microstructure, the material still lacks adequate damage tolerance properties compared to the conventional Nickel (Ni)-base superalloy that is generally used in this section of gas turbine engines.
- The MoC possessed a duplex microstructure consisting of mostly colonies of lamellae and isolated single phase gamma grains.
- Fatigue test conducted in this laboratory on the MoC of LPT 3<sup>rd</sup> stage blades showed that the material does not have enough crack growth resistance and after initiation, the crack propagates instantaneously leading to fracture.

### **1.17 Organisational and Management Information**

The aircraft is operated by an Indian registered Scheduled airline and are one of the launch customers for the Airbus A320 aircraft fitted with Neo engines. It operates scheduled flights to both domestic and international sectors.

M/s Indigo is a scheduled airline operating Domestic & International flights. It has got a fleet of Airbus A320/A321 and ATR-72 aircraft.

The A320 family aircraft operated by M/s Indigo are fitted with engines manufactured by Pratt & Whitney, USA.

As of November 2020, M/s Indigo has a total fleet of 140 (A320/A321) Neo aircraft.

The operator first inducted Neo aircraft in the year 2016. Initially, a total of 14 Neo aircraft were inducted by M/s Indigo in the year 2016.

The year wise induction of NEO fleet (Graphical Representation) by M/s Indigo is shown below: -



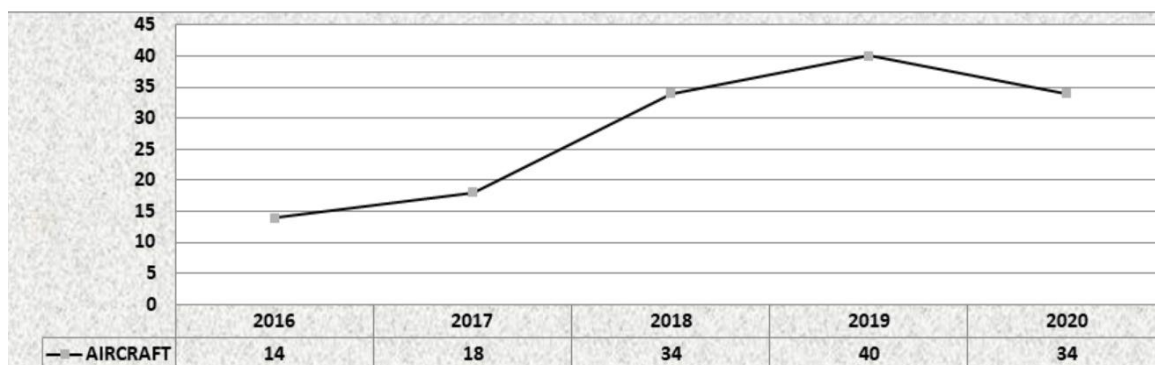

**Figure 4: Year wise induction of NEO fleet**

## 1.18 Additional Information

### 1.18.1 Typical Snags Reported in PW1127G-JM Engines

Since the induction of PW1127G-JM engines in India in the year 2016, there have been a number of snags reported on aircraft fitted with these engines. Most of the snags were repetitive in nature. In order to prevent reoccurrence of such failures, Pratt & Whitney came up with some rectification actions/modifications for each snag.

The following table depicts the Typical Snags and Rectification Action/Modification carried out by Pratt & Whitney along with the status of action taken by M/s Indigo as of 17<sup>th</sup> Nov 2020: -

S. No.	Typical Snag Reported	Rectification Action proposed by P&W	Action Taken by M/s Indigo (As of 17 <sup>th</sup> Nov 2020)
1.	#3 bearing seal failure	Issued SB 72-00-087	All Indigo engines are post SB 72-00-0087.
2.	Combustor failure	Issued SB 72-00-0136	176 IGO engine are post SB 72-00-0136.
3.	Low Pressure Turbine failure	Issued SB 72-00-0111	All IGO engine are post SB 72-00-0111.
4.	N2 Vibration	SB 72-00138 was released to replace HPC stage 6 ring seal with modified one.	134 engines are flying with post mod HPC 6 ring seal
5.	MGB IDG/LSOP gear failure.	Issued SB 72-00-0129	30 engines are Pre SB-72-00-0129.

**Table2: Typical Engine Failures and Rectification Action by Pratt & Whitney.**

The typical engine failures discussed in above para led to significant occurrences like In-Flight Shut Down (IFSD), Air Turn Back (ATB), Ground Turn Back (GTB), Rejected Take-Off (RTO), etc. The type and number of occurrences (Involving Indigo & Go Air aircraft) corresponding to each of the typical engine failures are listed below: -

<b>Type of Failure</b> →	# 3 bearing seal failure	Combustor failure	LPT failure	N2 Vibration	MGB IDG/LSOP gear failure.
<b>Type of Event</b> ↓					
<b>RTO (Rejected Take-off)</b>	Nil	1	Nil	2	Nil
<b>Engine Stall</b>	Nil	Nil	1	Nil	Nil
<b>ATB (Air Turn Back)</b>	Nil	1	18	5	3
<b>GTB (Ground Turn Back)</b>	Nil	Nil	Nil	1	Nil
<b>Diversion</b>	Nil	Nil	6	1	1
<b>Diversion/ATB</b>	Nil	Nil	Nil	Nil	Nil
<b>Emergency Landing</b>	1	Nil	Nil	Nil	Nil

**Table 3. Type of Occurrences corresponding to each engine failure.**

Out of the significant occurrences mentioned in the table above, 18 occurrences were classified as serious incidents by AAIB and Annex 13 investigation were instituted to investigate these serious incidents. Further distribution of these 18 serious incidents corresponding to type of failure is as below: -

<b>Type of Failure</b>	<b>Number of Serious Incidents</b>
<b>#3 bearing seal failure</b>	01
<b>LPT failure</b>	15
<b>N2 Vibration</b>	01
<b>MGB IDG/LSOP gear failure.</b>	01

**Table 4. Number of serious incidents corresponding to type of failures.**

As per the above table, it can be seen that majority of these serious incidents corresponds to LPT failure wherein the Blades of 3<sup>rd</sup> Stage of LPT failed in flight. As per agreement between M/s Indigo and OEM, the damaged engines were replaced by serviceable engines. All engines involved in the 18 serious incidents discussed above were quarantined after the occurrence and sent to OEM (Pratt & Whitney) facility in USA and Germany for repair. Pratt and Whitney did not subject any of these engines to any technical investigation as the events were similar to various prior occurrences and considered to be

a known issue. The Shop Visit report of all these Engine was shared with AAIB through Accredited Representative of NTSB.

### **1.18.2 Service Bulletin 72-00-0111**

Service Bulletin (SB) on “Engine - Disk, LPT 3rd Stage and Blade, LPT 3rd Stage and Shroud-Segment, Ring, 3rd Stage - Introduction of a New LPT 3rd Stage Blade which is more resistant to Impact Damage”. The SB was initially issued on 14th May 2019, thereafter Issue 2 was issued on 18th October 2019 and finally, Issue 3 was issued on 28th May 2020.

The reason for issue of this SB was given as “LPT 3rd stage blades fractured in service due to impact damage”. The cause of failure was given as “The LPT 3rd stage blade material is sensitive to impact damage.” The solution to this failure was given as “Introduction of a new LPT 3rd stage blade made of a different material which is more resistant to impact damage.”

The SB required that the LPT 3rd stage disk, blades, locking plates, and shroud segments be replaced by the new set made of different material.

### **1.18.3 Guidelines/Deadline given & action taken by DGCA.**

DGCA issued a deadline (to M/s Indigo) stating that, each A320 NEO aircraft with PW1127G-JM engine (where both engines of which has done more than 2900 FH) must have at least one LPT modified engine installed forthwith. Further, it stated that, all the A320 NEO aircraft fitted with Pratt and Whitney engines must have LPT modified for both its engines by 31st January 2020.

On 25th November 2019, DGCA issued an order stating that the new aircraft which has been inducted will slip into the role of one existing aircraft with unmodified (LPT) engines. It was also stated that no leased engines without modified LPT 3rd stage shall be imported. Thereafter, DGCA on 19th December 2019 issued an order stating that the order dated 25th November 2019 and 16th December 2019 will be kept in abeyance to the extent of grounding an existing aircraft with both unmodified engines upon induction of new aircraft in the fleet of Indigo. However, it said all other advisories issued by DGCA regarding the same will continue to remain in force.

DGCA issued order dated 13th January 2020 in which they extended the deadline of replacement of un-modified engines with modified engines to 31st May 2020. Later on,

27th May 2020, DGCA issued yet another order wherein the deadline was further extended to 31st August 2020 keeping in view of the COVID19 pandemic.

By 26th August 2020 all the PW1127G-JM engines (280 engines) of Indigo had complied with SB 72-00-0111 i.e., all its NEO fleet (140 aircraft) were installed with LPT modified engines.

### **1.19 Useful or Effective Investigation Techniques**

Nil

## **2 ANALYSIS**

### **2.1 General**

- Both pilots were appropriately licensed and qualified to operate the flight.
- The aircraft had a valid Certificate of Airworthiness at the time of incident. The Aircraft held a valid Certificate of Release to Service which was issued at the airport of departure. Airworthiness Directives & Service Bulletins were complied with. Transit Inspections were carried out as per the approved Transit Inspection Schedules and all higher Inspection Schedules including checks/inspection as per the manufacturer's guidelines and specified in Maintenance Programme.

### **2.2 Circumstances Leading to the Incident**

VT-IZT was equipped with PW1127G-JM ESN # P771192. This engine was fitted with pre-modified LPT 3<sup>rd</sup> stage blades which had less crack growth resistance and impact tolerance. The aircraft suffered LPT 3<sup>rd</sup> stage blade failure while climbing passing Flight Level 283. A loud bang was heard by the crew. Subsequently, ENG 2 STALL ECAM triggered. This was followed by "ENG 2 HGH VIB" on ECAM. The crew followed QRH/FCOM procedure. Thereafter, ENG 2 EGT OVERLIMIT also triggered on ECAM. As the Engine parameters were abnormal, the crew decided to divert back to Delhi. The crew then carried out "Commanded IFSD" of Engine # 2 during descent.

Accordingly, crew informed ATC, Delhi and after obtaining necessary clearances from ATC, the aircraft landed back safely at Delhi with single engine. During post flight inspection while carrying out visual inspection of the involved engine, LPT 3<sup>rd</sup> stage blades were found damaged.

Incident was one amongst series of similar events and hence Pratt and Whitney did not carry out Technical Investigation into this case.

## **2.3 LPT 3<sup>rd</sup> stage blade failure and preventive action.**

Based on the analysis by NAL, Bengaluru to study Material of Construction (MoC) it was determined that the pre-modified LPT stage 3 blades are made of gamma-based Titanium Aluminide (TiAl) which is, in general, brittle in nature having low fracture toughness. Although, the alloy used for LPT blades 3<sup>rd</sup> stage blades is an improved version of TiAl alloys with engineered microstructure, the material still lacked adequate damage tolerance properties. It was confirmed during the fractography study conducted by NAL, Bengaluru that LPT 3<sup>rd</sup> stage blades of the Engine ESN 770187, 770530 and 770516 had fractured instantaneously in a brittle manner and none of the blades showed presence of any signatures of progressive failure such as fatigue. The fatigue test further confirmed that the material does not have enough crack growth resistance and after initiation, the crack propagated instantaneously leading to fracture. It is, therefore, evident that the LPT stage 3 blades failed in flight as these blades could not withstand possible impact from material liberated upstream and got fractured instantaneously. This led to engine high vibration and EGT overlimit.

Subsequent to directions issued by the DGCA to equip all aircraft with LPT modified engines, the airlines complied with SB 72-00-0111 and all its A320 NEO fleet (140 aircraft) were installed with LPT modified engines.

## **3.0 CONCLUSION**

### **3.1 Findings**

1. The aircraft had valid Certificate of Airworthiness, Certificate of Registration and the Certificate of Flight Release before operating the incident flight.
2. Both pilots were appropriately qualified to operate the flight.
3. There was no fire and no injury to any occupant on board the aircraft.
4. During post flight inspection, while carrying out visual inspection of the involved engine, i.e., inlet area and exhaust area of Engine # 2, Low Pressure Turbine 3<sup>rd</sup> stage blades were found damaged.
5. The incident was similar to series of other events where LPT 3<sup>rd</sup> stage blades failed during operation. The failure was considered to be a known issue by the OEM and no Technical Investigation was carried out by the OEM.
6. Failure Analysis of blades at NAL, Bengaluru indicated that the LPT 3<sup>rd</sup> stage blades material had less crack growth resistance and damage tolerance which causes the crack to propagate instantaneously after initiation leading to fracture.

7. Pratt & Whitney has issued SB 72-00-0111 to Introduce of a new LPT 3rd stage blade made of a different material which is more resistant to impact damage. The airline has incorporated the said SB in all its affected aircraft.

### **3.2 Probable Cause of the Incident**

The incident was caused by failure of LPT 3<sup>rd</sup> stage blades in flight as the blade material lacked crack growth resistance and damage tolerance to withstand any impact from material that may have liberated upstream.

### **4.0 SAFETY RECOMMENDATIONS**

4.1 In view of corrective action initiated by the OEM to introduce new blades with better impact resistance and subsequent compliance by the Airline no recommendation is made.

**-S/d-**

**K Ramachandran  
Investigator - In - Charge**

**-S/d-**

**Amit Kumar  
Investigator**